



Assembly Instructions of Racking Systems

191 Post Road West, Westport, CT 06880 www.sungaldisplay.com

Any questions about parts or installation, please contact Sungal Customer Service at (203) 505-3479

Note: For a 27" deep racking system allow three key holes at both front and rear for a 5.5° pitch; for a 36" deep racking system allow three key holes at front and four key holes at rear creates a pitch of 7.4°.

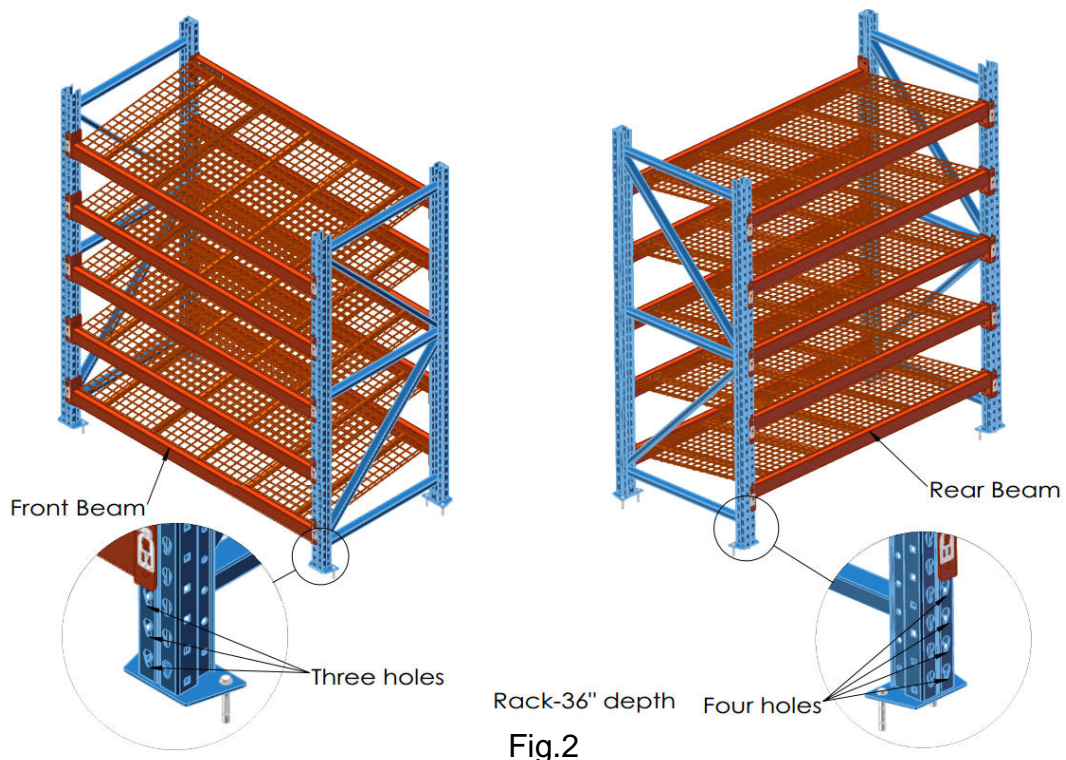
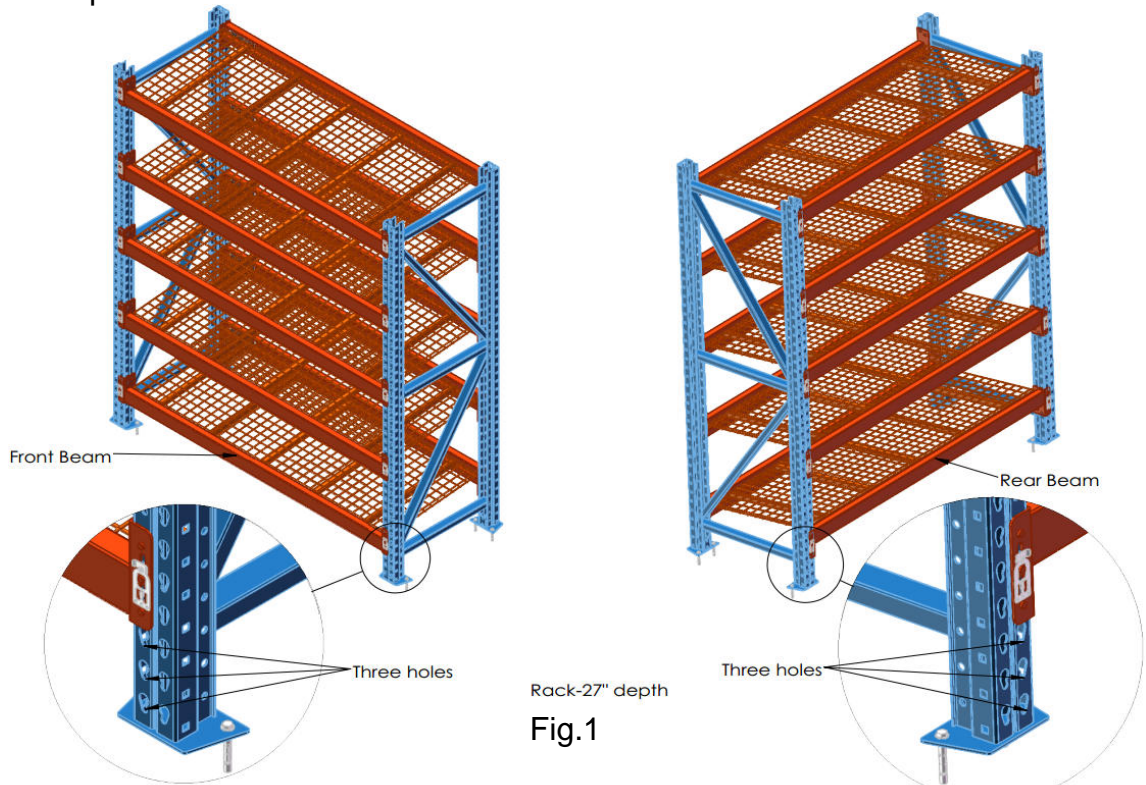

Step 1: Assembly of Upright Frames and Front/Rear Beams

Attach front and rear cross beams to standing upright frames. See the Note first to set up the rear beam for an appropriate pitch. Make sure attachment pins are secured in the key-hole slots.

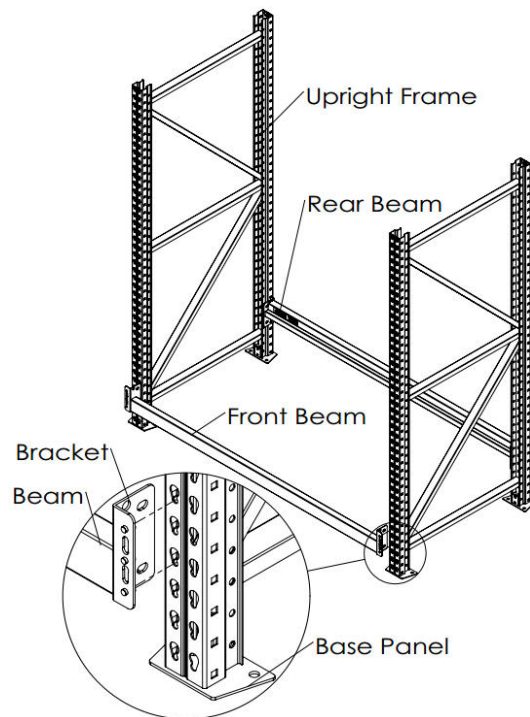

Fig.3

Step 2: Insert bolts into holes of base panels to secure uprights to the ground

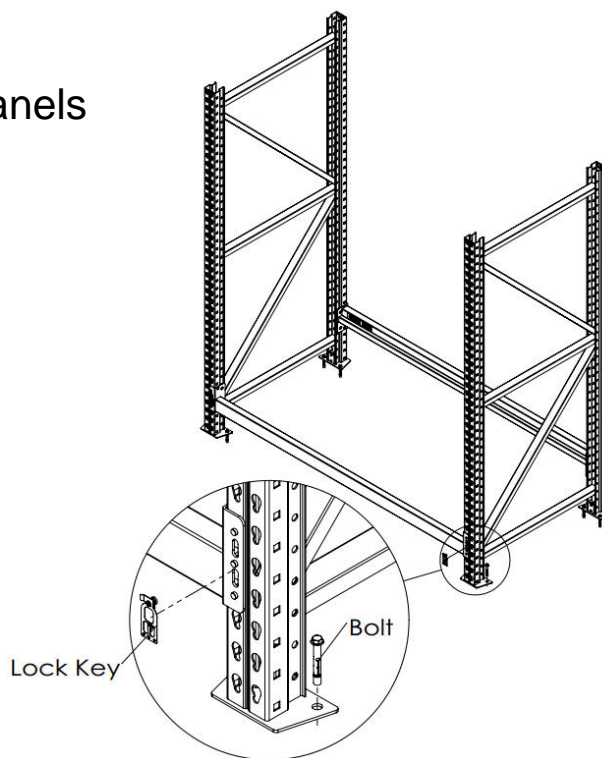

Fig.4

Step 3: Integrate all front and rear beams to standing upright frames to complete the set-up of racking system

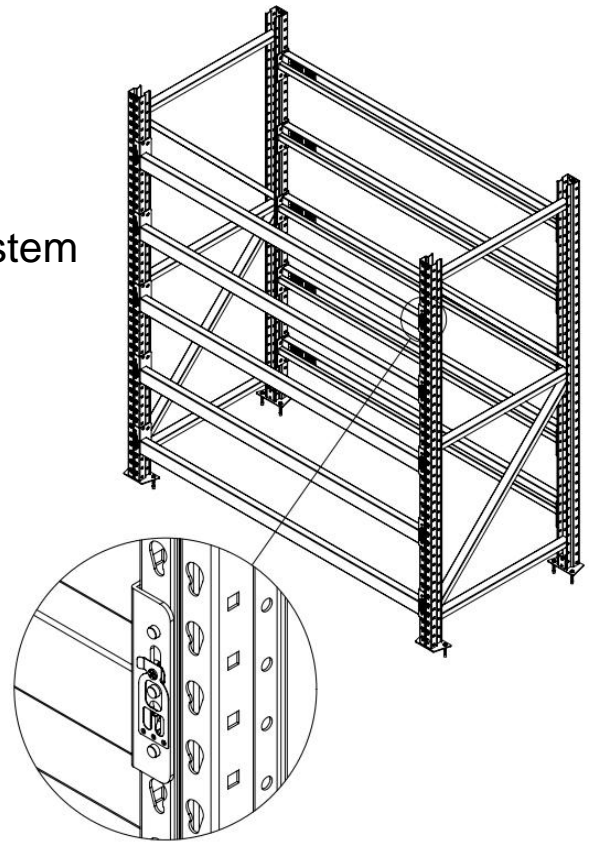

Fig.5

Step 4: Place and secure wire shelves on front and rear beams at an appropriate pitch.

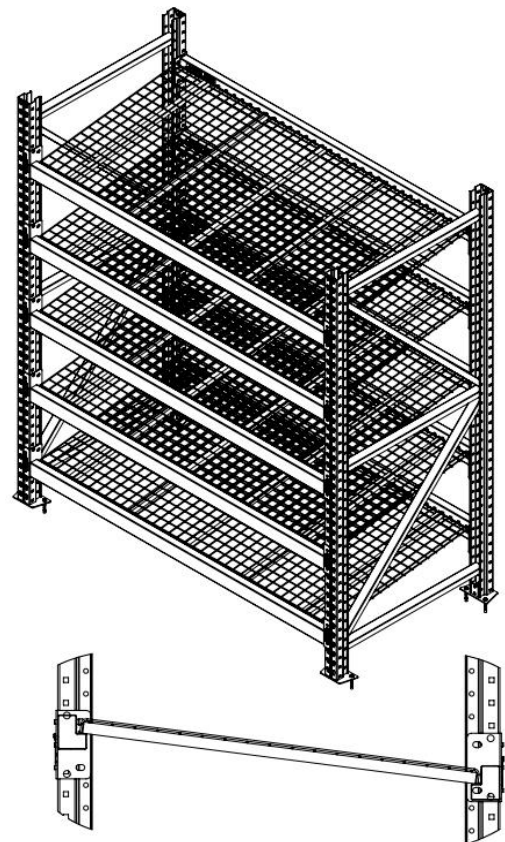

Fig.6

Step 5 Place Roller Mats on the Required Wire Shelf

Make sure that the 15" wide roller mat is placed in the middle and the 28 1/2" wide roller mat are placed at each side. Place front steel L-guards along the front beam before install roller mat.

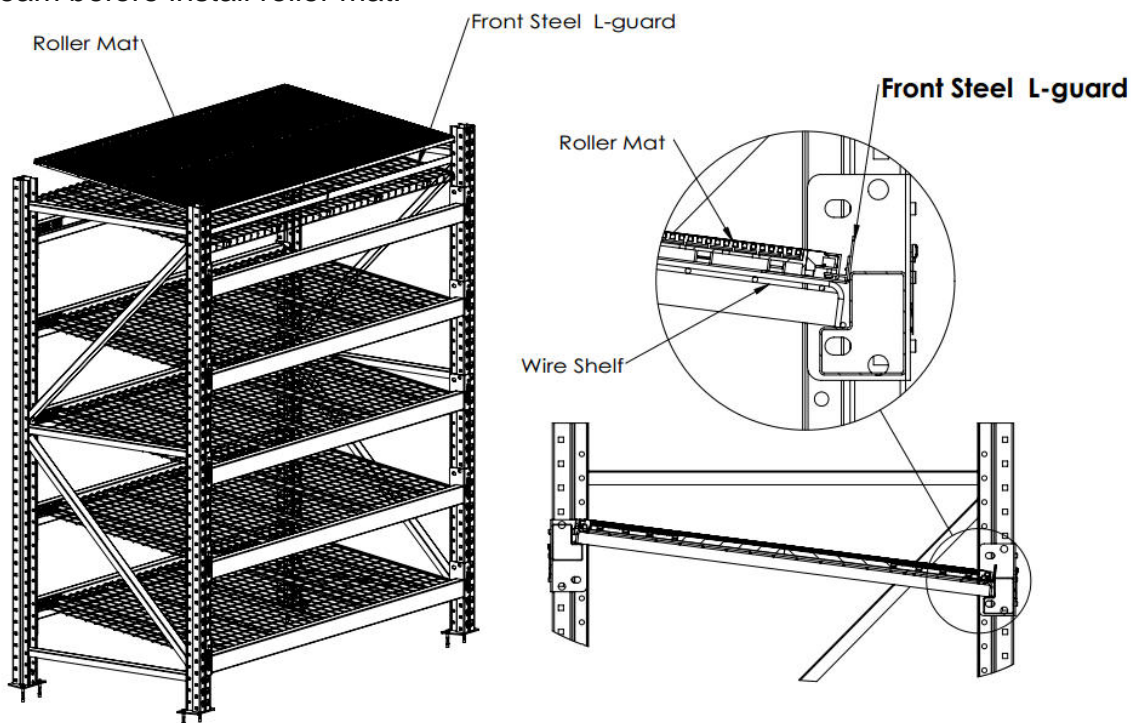

Fig.7

Step 6 Snap Front Rails into the U-channel of Front Aluminum Extrusion

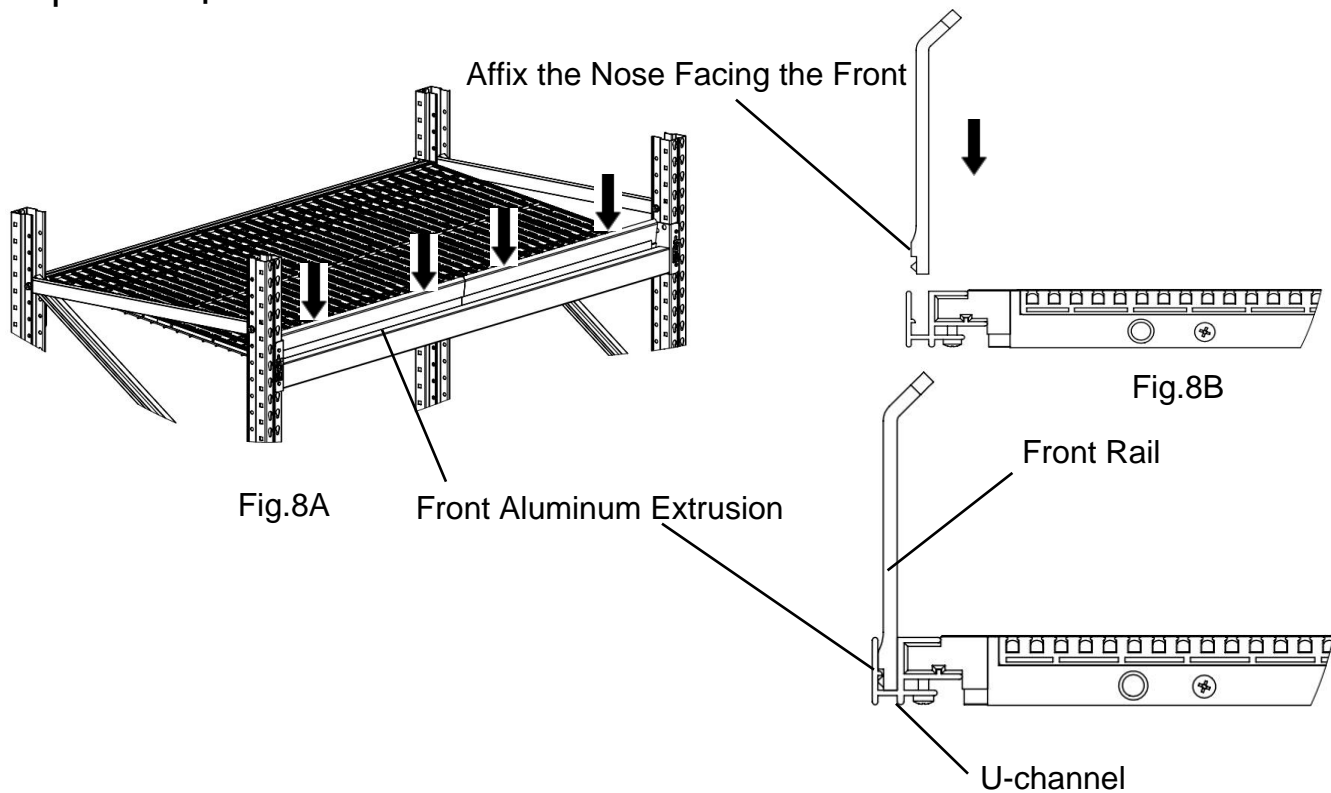

Fig.8B

Fig.8C

Step 7 Install Front Steel L-guards

Make sure that front steel L-guards are placed completely beneath roller mat.

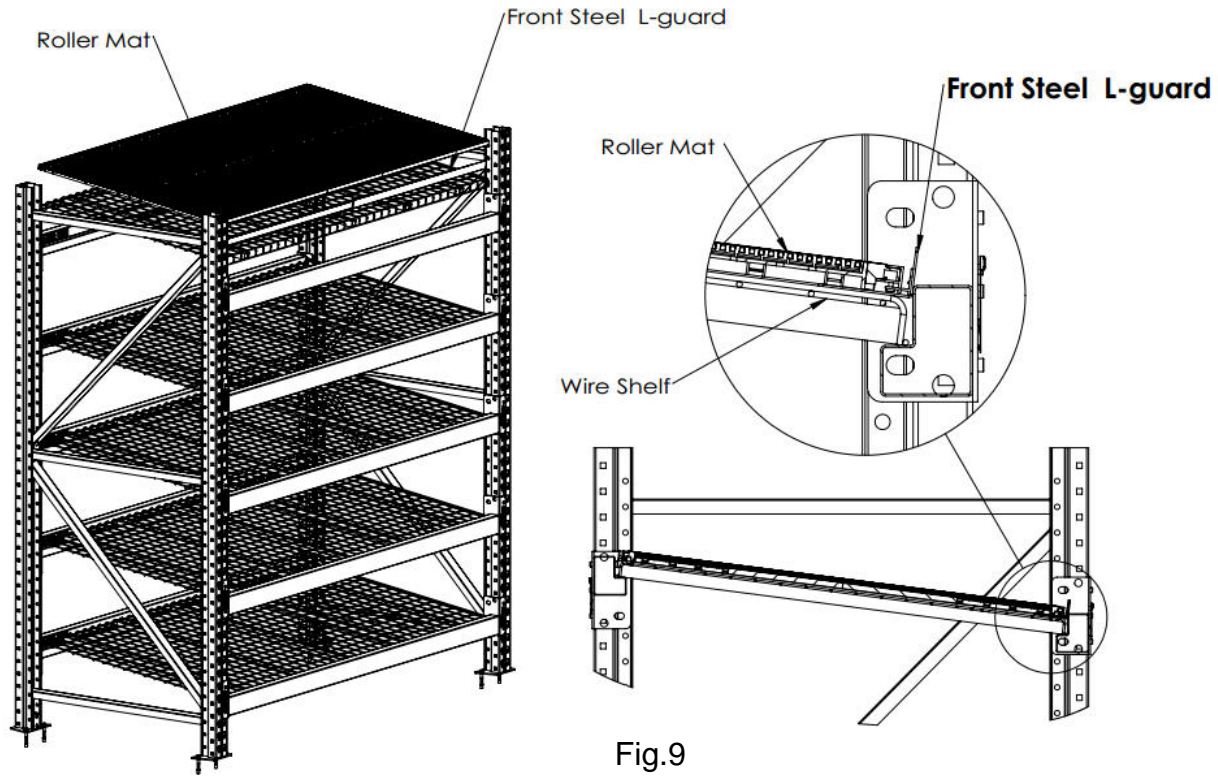

Fig.9

Step 8 Install Wire Dividers

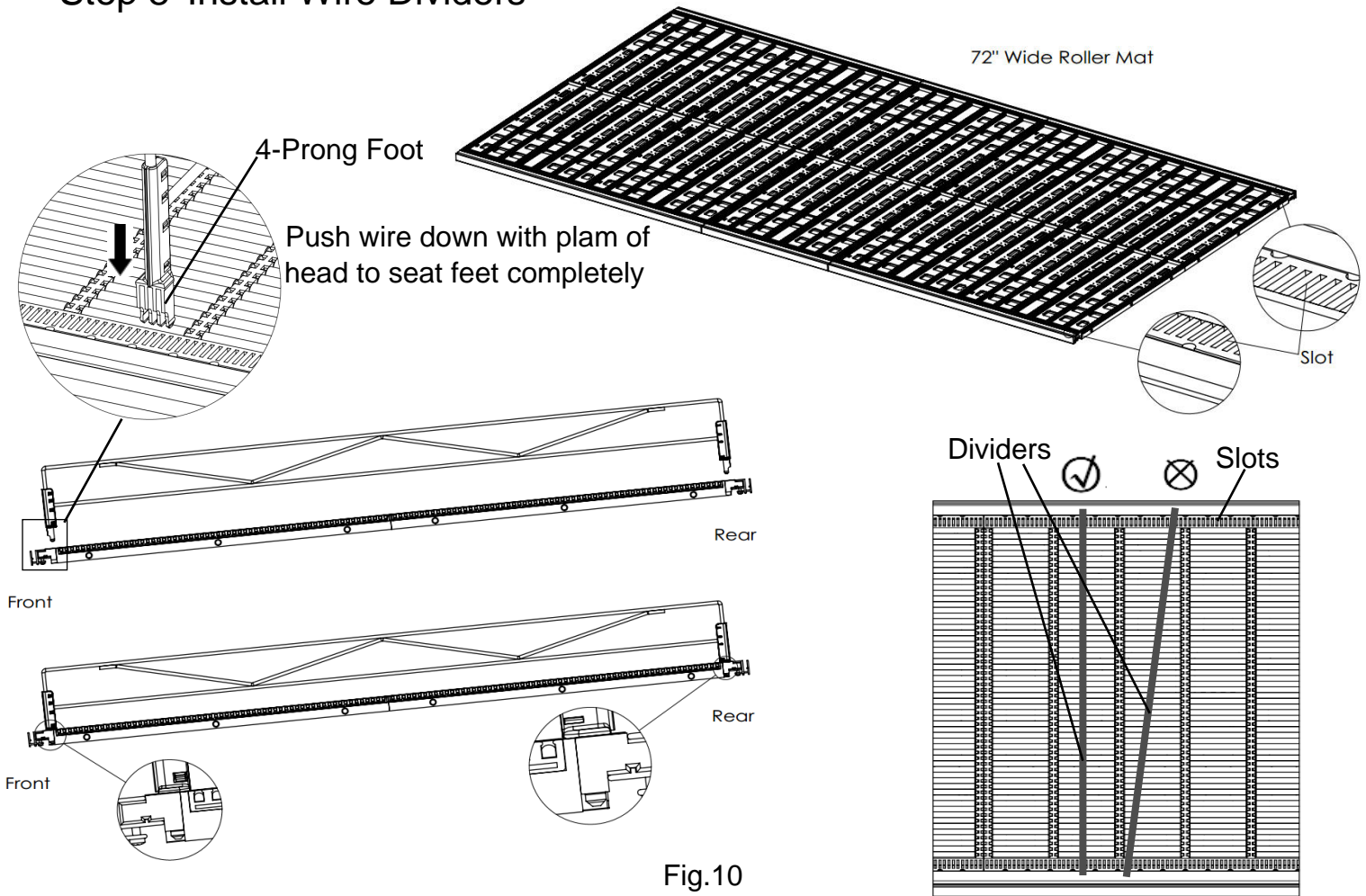

Fig.10