

# SUNGAL ROLLER SHELF FOR HILL PHOENIX OPEN COOLER SYSTEM

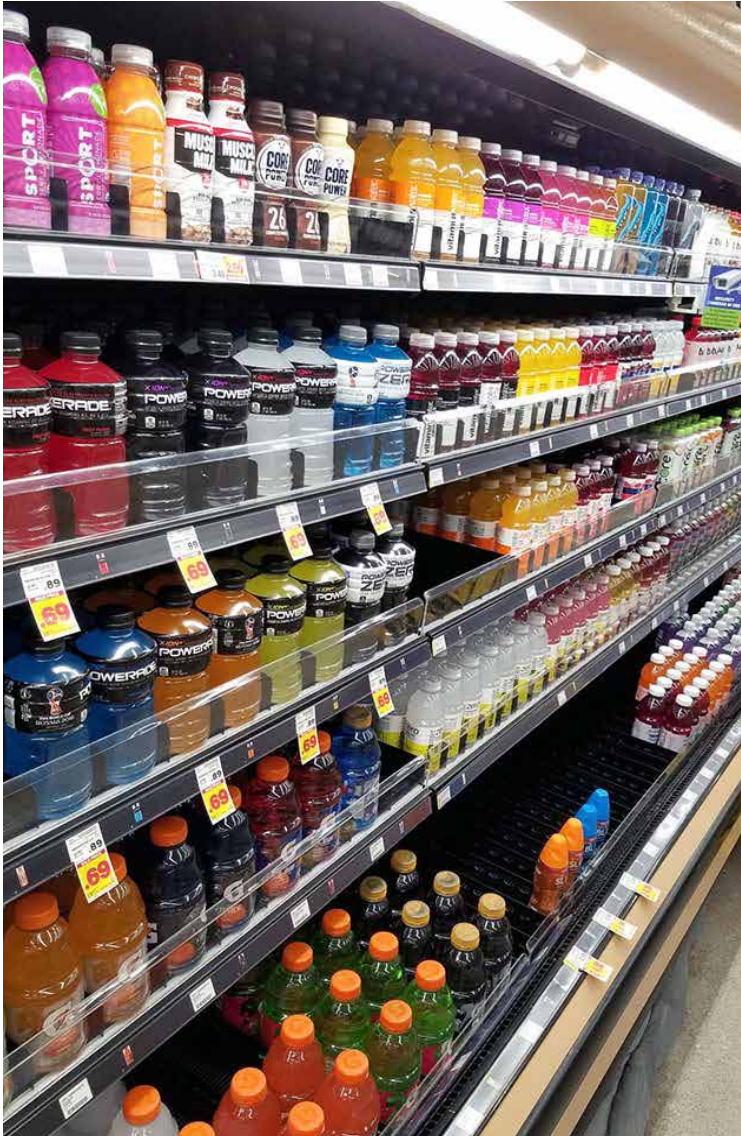

- Sungal roller shelves have a patented design and are the NSF-listed roller system
- Minimum angle of inclination: 4°. Provides better visual impact with better sight lines than other gravity feed systems. Replaces cumbersome, spring pusher systems
- 2-Piece structure comprising of one welded metal base frame and one top roller mat for reliable support, and easier installation.
- Snap-in rollers for easier replacement from top surface
- Sungal roller shelves have drains to deter fluid from rendering rollers inoperative
- 2-Piece structure is easier to clean: simply remove plastic roller mat and pressure-wash
- 5-year warranty



Intertek



## Sungal Roller Shelf Kits for Hill Phoenix Coolers

- All 36" kits Include
  - (1) Sungal shelf 36" (w) frame
  - (1) Sungal 36" (w) roller mat
  - (1) Sungal 3 1/2" (h) x 36" (w) clear plastic front retainer
  - (1) Sungal 1" (h) x 36" (w) clear plastic rear retainer
  - (14) Sungal 2" (h) metal dividers

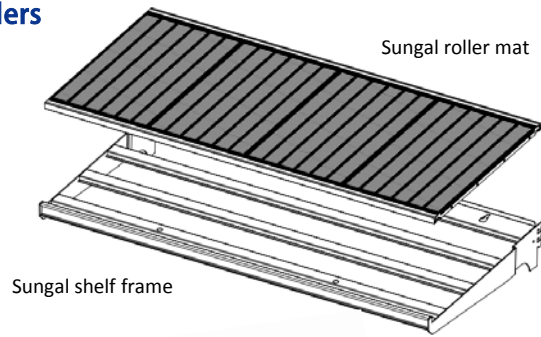

- All 48" kits Include
  - (1) Sungal shelf 48" (w) frame
  - (1) Sungal 48" (w) roller mat
  - (1) Sungal 3 1/2" (h) x 48" (w) (3 1/2" (h) x 48" (w)) clear plastic front retainer
  - (1) Sungal 1" (h) x 36" (w) (1" (h) x 36" (w)) clear plastic rear retainer
  - (18) Sungal 2" (h) metal dividers

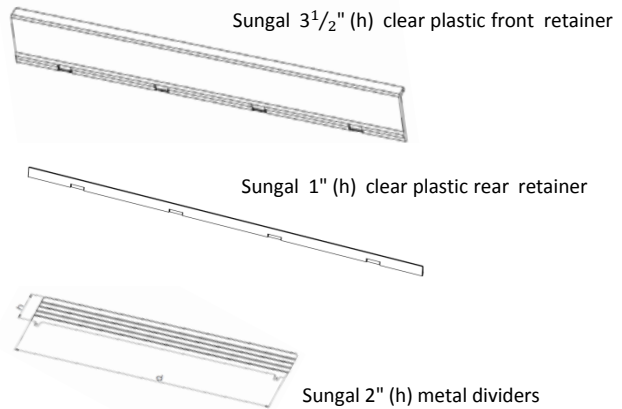

- SRBC-4816-HP-K-BLK (48" (w) x 16" (d))
- SRBC-4818-HP-K-BLK (48" (w) x 18" (d))
- SRBC-4820-HP-K-BLK (48" (w) x 20" (d))
- SRBC-4822-HP-K-BLK (48" (w) x 22" (d))
- SRBC-4824-HP-K-BLK (48" (w) x 24" (d))
- SRBC-3616-HP-K-BLK (36" (w) x 16" (d))
- SRBC-3618-HP-K-BLK (36" (w) x 18" (d))
- SRBC-3620-HP-K-BLK (36" (w) x 20" (d))
- SRBC-3622-HP-K-BLK (36" (w) x 22" (d))
- SRBC-3624-HP-K-BLK (36" (w) x 24" (d))

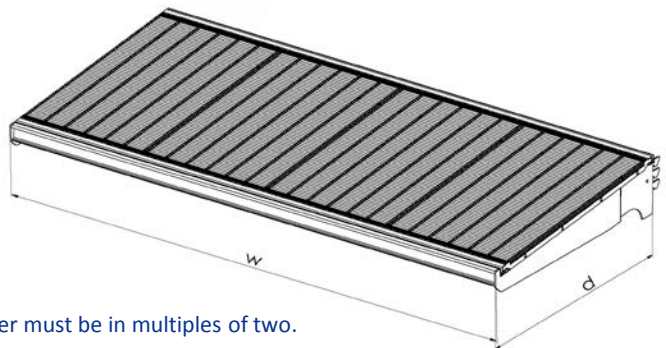

Note: All shelf kits are packed two per carton only, order must be in multiples of two.

## Sungal Roller Deck Shelves for Cooler

- Includes
  - SRDC-4816 -K-BLK (48" (w) x 16" (d))
  - SRDC-4818 -K-BLK (48" (w) x 18" (d))
  - SRDC-4820 -K-BLK (48" (w) x 20" (d))
  - SRDC-4822 -K-BLK (48" (w) x 22" (d))
  - SRDC-4824 -K-BLK (48" (w) x 24" (d))
  - SRDC-3616 -K-BLK (36" (w) x 16" (d))
  - SRDC-3618 -K-BLK (36" (w) x 18" (d))
  - SRDC-3620 -K-BLK (36" (w) x 20" (d))
  - SRDC-3622 -K-BLK (36" (w) x 22" (d))
  - SRDC-3624 -K-BLK (36" (w) x 24" (d))

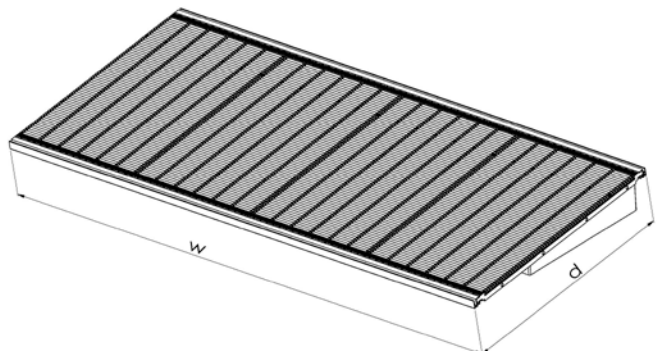

## Optional Accessories

### Sungal Roller Mats for Sungal Roller Shelves

- Includes
  - SRM-4816 -K-BLK (48" (w) x 16" (d))
  - SRM-4818 -K-BLK (48" (w) x 18" (d))
  - SRM-4820 -K-BLK (48" (w) x 20" (d))
  - SRM-4822 -K-BLK (48" (w) x 22" (d))
  - SRM-4824 -K-BLK (48" (w) x 24" (d))
  - SRM-3616 -K-BLK (36" (w) x 16" (d))
  - SRM-3618 -K-BLK (36" (w) x 18" (d))
  - SRM-3620 -K-BLK (36" (w) x 20" (d))
  - SRM-3622 -K-BLK (36" (w) x 22" (d))
  - SRM-3624 -K-BLK (36" (w) x 24" (d))

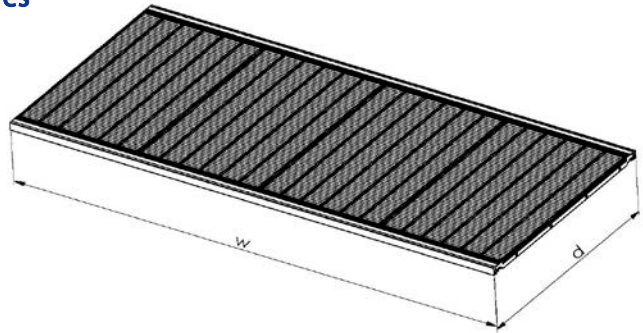

### Metal Dividers for Sungal Roller Shelves

- Includes
  - SDM-116-25PK-BLK (1" (h) x 16" (d))
  - SDM-216-25PK-BLK (2" (h) x 16" (d))
  - SDM-118-25PK-BLK (1" (h) x 18" (d))
  - SDM-218-25PK-BLK (2" (h) x 18" (d))
  - SDM-120-25PK-BLK (1" (h) x 20" (d))
  - SDM-220-25PK-BLK (2" (h) x 20" (d))
  - SDM-122-25PK-BLK (1" (h) x 22" (d))
  - SDM-222-25PK-BLK (2" (h) x 22" (d))
  - SDM-124-25PK-BLK (1" (h) x 24" (d))
  - SDM-224-25PK-BLK (2" (h) x 24" (d))

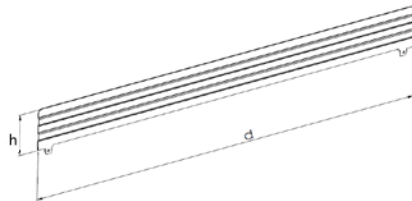

### Wire Dividers for Sungal Roller Shelves

Custom made

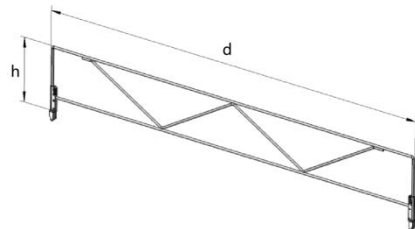

Standard: 4-pronged feet for wire dividers

### Clear Plastic Front/Rear Retainers for Sungal Roller Shelves

- Includes
  - SFR-136-25PK (1" (h) x 36" (w))
  - SFR-148-25PK (1" (h) x 48" (w))
  - SFR-236-25PK (2" (h) x 36" (w))
  - SFR-248-25PK (2" (h) x 48" (w))
  - SFR-336-H-25PK (3<sup>1</sup>/<sub>2</sub>" (h) x 36" (w))
  - SFR-348-H-25PK (3<sup>1</sup>/<sub>2</sub>" (h) x 48" (w))
  - SFR-436-H-25PK (4<sup>1</sup>/<sub>2</sub>" (h) x 36" (w))
  - SFR-448-H-25PK (4<sup>1</sup>/<sub>2</sub>" (h) x 48" (w))
- Transparent and durable
- Snaps in easily

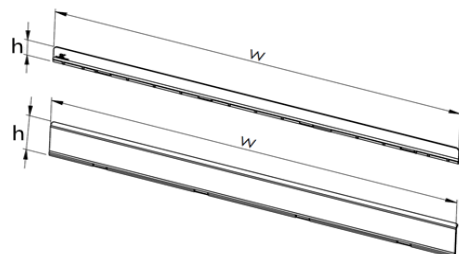

# Remarks

Middle

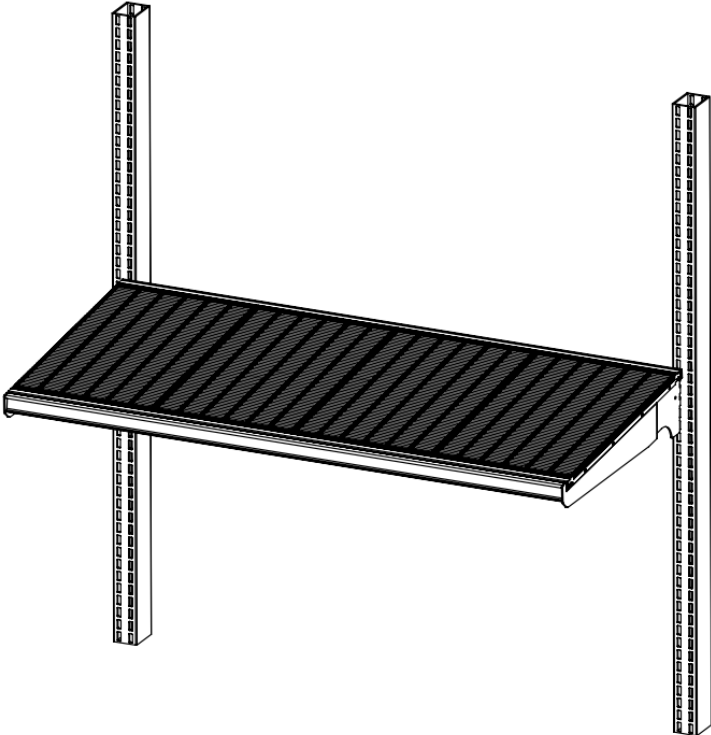

End

